

K2/SB28

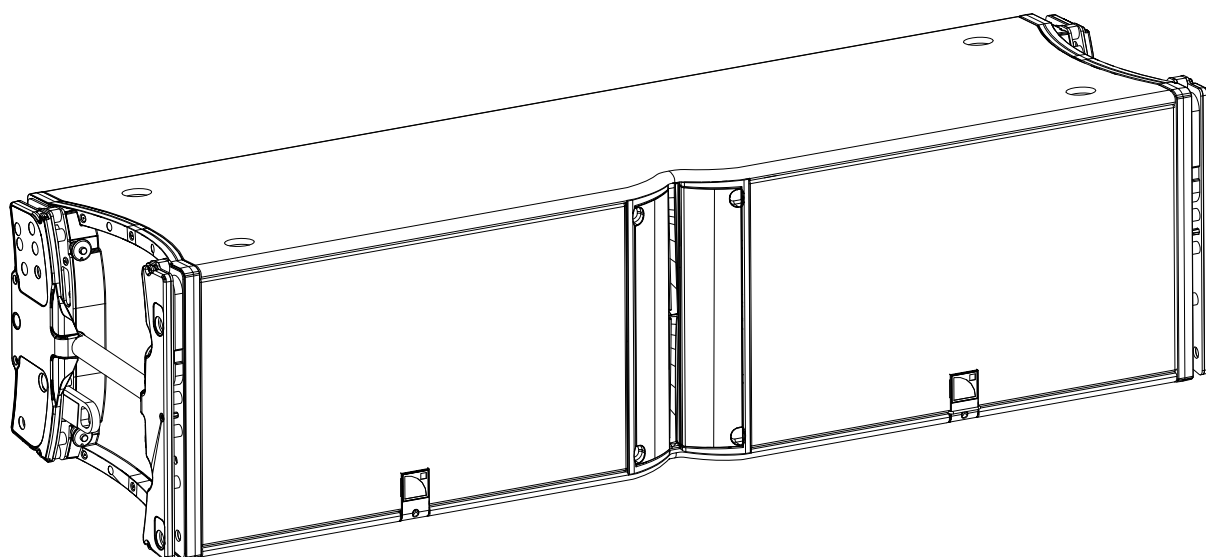

user manual (EN)



Document reference: K2/SB28 user manual (EN) version 7.0

Distribution date: May 4, 2018

© 2018 L-Acoustics. All rights reserved.









No part of this publication may be reproduced or transmitted in any form or by any means without the express written consent of the publisher.

Contents

Safety.....	4
Instructions.....	4
Symbols.....	4
Welcome.....	5
System components.....	6
Technical description.....	8
K2 horizontal directivity settings.....	8
K1-SB applications.....	9
Loudspeaker configurations.....	10
Line source.....	10
Additional subwoofer system.....	12
K1-SB.....	13
SB28.....	16
Additional downfill element.....	18
Kara.....	18
Loudspeaker connection.....	19
Connectors.....	19
Connection to LA4X.....	21
Connection to LA8.....	22
Preset description.....	25
Recommendation for speaker cables.....	26
Specifications.....	27
K2 specifications.....	27
Kara specifications.....	29
K1-SB specifications.....	31
SB28 specifications.....	33



Safety

Instructions

- 
Inspect the product before operation.
 If any sign of defect or damage is detected, immediately withdraw the product from use for maintenance.
- 
Never incorporate equipment or accessories not approved by L-Acoustics.
Read all the related PRODUCT INFORMATION documents shipped with the products before exploiting the system.
- 
Do not store the product on an unstable cart, stand, tripod, bracket, or table.
- 
Beware of sound levels.
 Do not stay within close proximity of loudspeakers in operation.
 Loudspeaker systems are capable of producing very high sound pressure levels (SPL) which can instantaneously lead to permanent hearing damage to performers, production crew and audience members. Hearing damage can also occur at moderate level with prolonged exposure to sound.
 Check the applicable laws and regulations relating to maximum sound levels and exposure times.
- 
This system is intended for professional use.
- 
Read the RIGGING MANUAL before installing the system.
 Use the rigging accessories described in the rigging manual and follow the associated procedures.
Read the maintenance section of this document before servicing the product.
- 
Do not expose the product to extreme conditions.
 Do not expose the product to rain or sea spray.
 Do not expose the product to moisture (mist, steam, humidity, condensation...) or excessive heat (direct sun, radiator...) for a long period of time.
- 
Contact L-Acoustics for advanced maintenance.
 Any unauthorized maintenance operation will void the product warranty.

Symbols

The following symbols are used in this document:

- 
 This symbol indicates a potential risk of harm to an individual or damage to the product.
 It can also notify the user about instructions that must be strictly followed to ensure safe installation or operation of the product.
- 
 This symbol notifies the user about instructions that must be strictly followed to ensure proper installation or operation of the product.
- 
 This symbol notifies the user about complementary information or optional instructions.

Welcome

Thank you for purchasing the L-Acoustics K2.

This document contains essential information on using the system properly.

As part of a continuous evolution of techniques and standards, L-Acoustics reserves the right to change the specifications of its products and the content of its document without prior notice. Please check www.l-acoustics.com on a regular basis to download the latest document and software updates.

K2 variable curvature WST line source

The K2 is the full range element of a WST[®] line source with variable curvature and adjustable horizontal directivity. The K2 loudspeaker enclosure is based on a 3-way active design. It comprises 4 input sections: 2 LF and 1 MF at a nominal impedance of 8 ohms, and 1 HF at a nominal impedance of 16 ohms. It features two 12" speakers and four 6.5", all direct-radiating neodymium speakers mounted in a bass-reflex enclosure, and two 3" neodymium diaphragm compression drivers coupled to individual DOSC[®] waveguides and adjustable directivity fins. The transducers are implemented in a K-shape configuration. The cabinet is made of machined first grade Baltic birch plywood (for top, bottom and back panels) combined to die cast aluminum side panels to ensure maximum acoustical and mechanical integrity while reducing weight to the minimum. A four-point rigging system is integrated into the cabinet.

The K2 enclosure operates over the nominal frequency range of 35 Hz to 20 kHz. Its LF contour can be reinforced with the dedicated K1-SB extension and its bandwidth can be extended down to 25 Hz with the SB28 subwoofer. In the horizontal plane, the directivity is adjustable down to 300 Hz, with two symmetric settings (70° or 110°) and two asymmetric settings (90° as 35°/55° or 55°/35°).

The K2 rigging system allows vertical assembly of enclosures with various inter-element angles (up to 10°), constituting a line array with variable curvature. The combination of the coplanar symmetry and the DOSC[®] waveguide in the HF region ensure a perfect acoustic coupling between the elements of an array. The WST[®] (Wavefront Sculpture Technology) criteria are fulfilled, so that such an array can be qualified as a true line source. Any WST[®] line source provides a smooth tonal response and a coverage that is free of secondary lobes over the entire frequency range.

The K2 is driven and quad-amplified by the LA8 or LA4X controller with factory presets which ensure linearization, protection, and optimization for the loudspeaker system.

System components

Loudspeaker enclosures

K2	3-way full-range active WST enclosure
K1-SB	K1 system subwoofer 2x15"
SB28	High power subwoofer: 2 x 18"
Kara	2-way modular WST enclosure

Powering and driving system

LA4X / LA8	Amplified controller with DSP, preset library and networking capabilities
LA-RAK	Touring rack containing three LA8 and power, audio and network distribution



Refer to the LA4X / LA8 user manual for operating instructions.

Loudspeaker cables

SP cables	4-point speakON loudspeaker cables (4 mm ² gauge) SP cables come in four sizes: SP.7 (0.7 m/2.3 ft), SP5 (5 m/16.4 ft), SP10 (10 m/32.8 ft) and SP25 (25 m/82 ft)
SP-Y1	breakout cable for two passive enclosures (2.5 mm ² gauge) provided with a CC4FP adapter 4-point speakON to 2 x 2-point speakON
DO	8-point PA-COM loudspeaker cables (4 mm ² gauge) DO cables come in three sizes: DO.7 (0.7 m/2.3 ft), DO10 (10 m/32.8 ft) and DO25 (25 m/82 ft)
DOSUB-LA8	breakout cable for four passive enclosures (4 mm ² gauge) 8-point PA-COM to 4 x 2-point speakON
DOFILL-LA8	breakout cable for two 2-way active enclosures (4 mm ² gauge) 8-point PA-COM to 2 x 4-point speakON
DO3WFILL	breakout cable for one 2-way active enclosure and two passive enclosures (4 mm ² gauge) 8-point PA-COM to 1 x 4-point speakON and 2 x 2-point speakON



Information about the connection of the enclosures to the LA amplifiers is given in this document.

Refer to the LA4X / LA8 user manual for detailed instructions about the whole cabling scheme, including modulation cables and network.

Rigging elements



Rigging elements or procedures are not presented in this document.
Refer to the K2 rigging manual.

Software applications

Soundvision 3D acoustical and mechanical modeling software

LA Network Manager Software for remote control and monitoring of amplified controllers

i Refer to the **Soundvision** help.

i Refer to the **LA Network Manager** help.

Loudspeaker cables

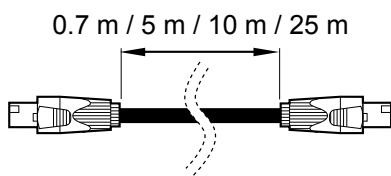

SP.7 / SP5 / SP10 / SP25

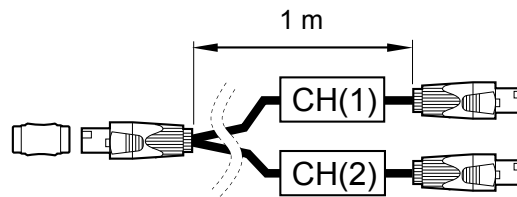

SP-Y1

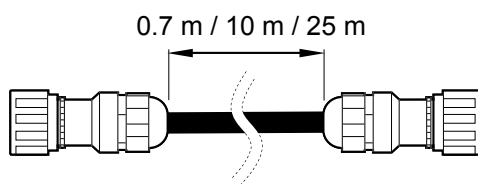

DO.7 / DO10 / DO25

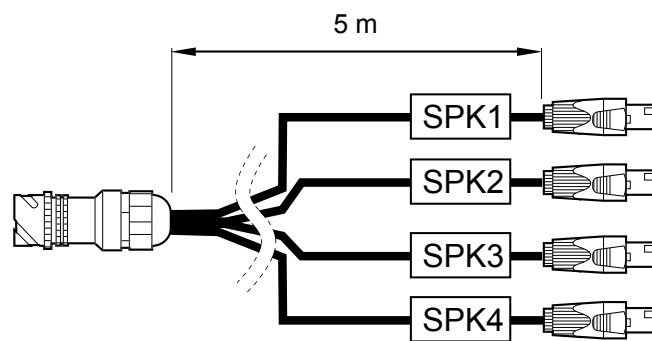

DOSUB-LA8

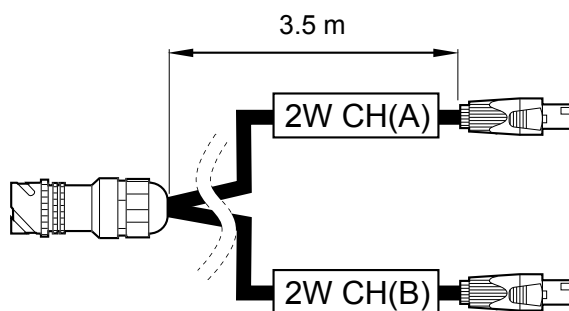

DOFILL-LA8

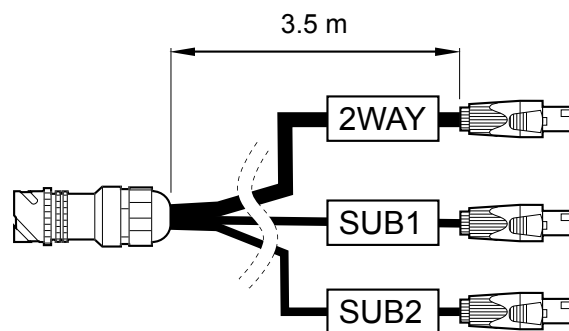

DO3WFILL

Technical description

K2 horizontal directivity settings

The K2 enclosure features an adjustable horizontal directivity system. Using the adjustable fins, horizontal directivity can be adjusted with four different settings: 110°/70° symmetric or 90° asymmetric (35°/55° or 55°/35°). A specific K2 preset must be used for each directivity setting.

Within a line source, different directivity settings can be combined to improve the coverage of the audience geometry.

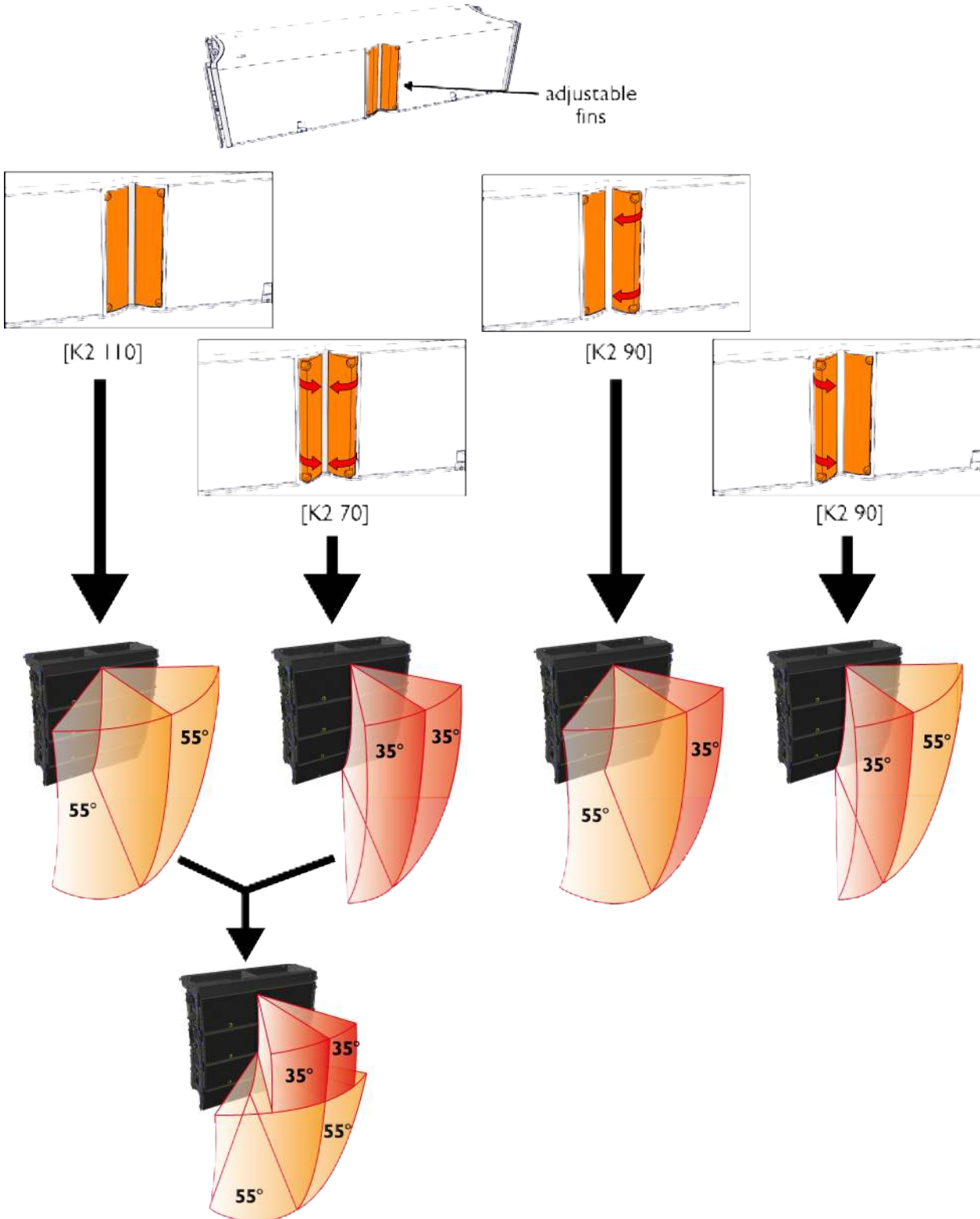

K1-SB applications

There are two distinct applications for K1-SB in a K2 system:

- As an LF extension in a line source for enhanced throw, using the [K1SB_X K2] preset with K2.
- As a subwoofer for increased impact, using the [K1SB_60] preset.

i Both applications of K1-SB can be combined in the same configuration.

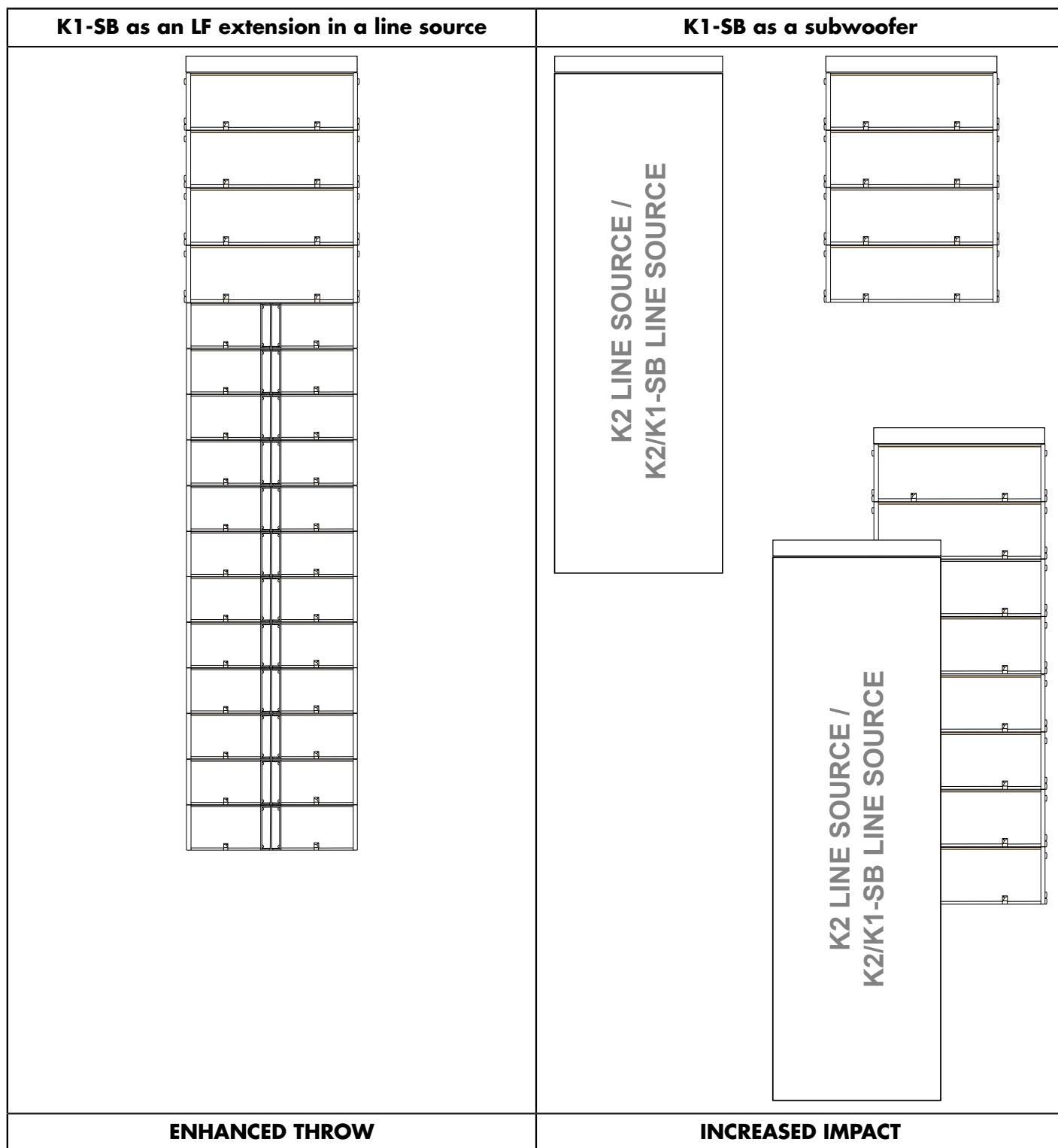

Loudspeaker configurations

Line source

Deployed as a line source, the system operates over the nominal bandwidth of the K2 enclosure, with an adjustable horizontal directivity.

Two configurations are possible:

- K2 line source
- K2/K1-SB line source: enhanced LF throw

The [K2 70], [K2 90] and [K2 110] presets allow for a reference frequency response in long throw applications. Each preset is dedicated to a horizontal directivity setting.

By providing the K1-SB with the same frequency response as the K2 low section, the [K1SB_X K2] preset allows the K1-SB enclosure to be used as an LF line source element, increasing the length of the sub-low line source.

The K2 enclosures are driven by the LA4X / LA8 amplified controllers.

The K1-SB enclosures are driven by the LA8 amplified controller.

Standalone K2 line source

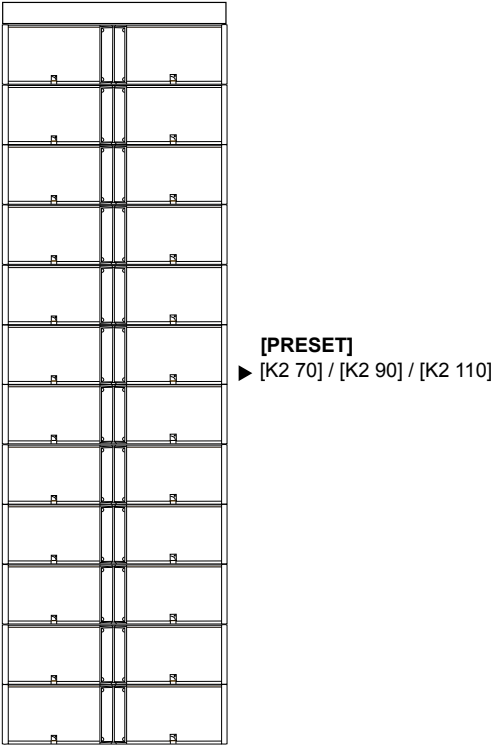
	
Enclosure	K2
Preset	[K2 70] [K2 90] [K2 110]
Frequency range (-10 dB)	35 Hz - 20 kHz

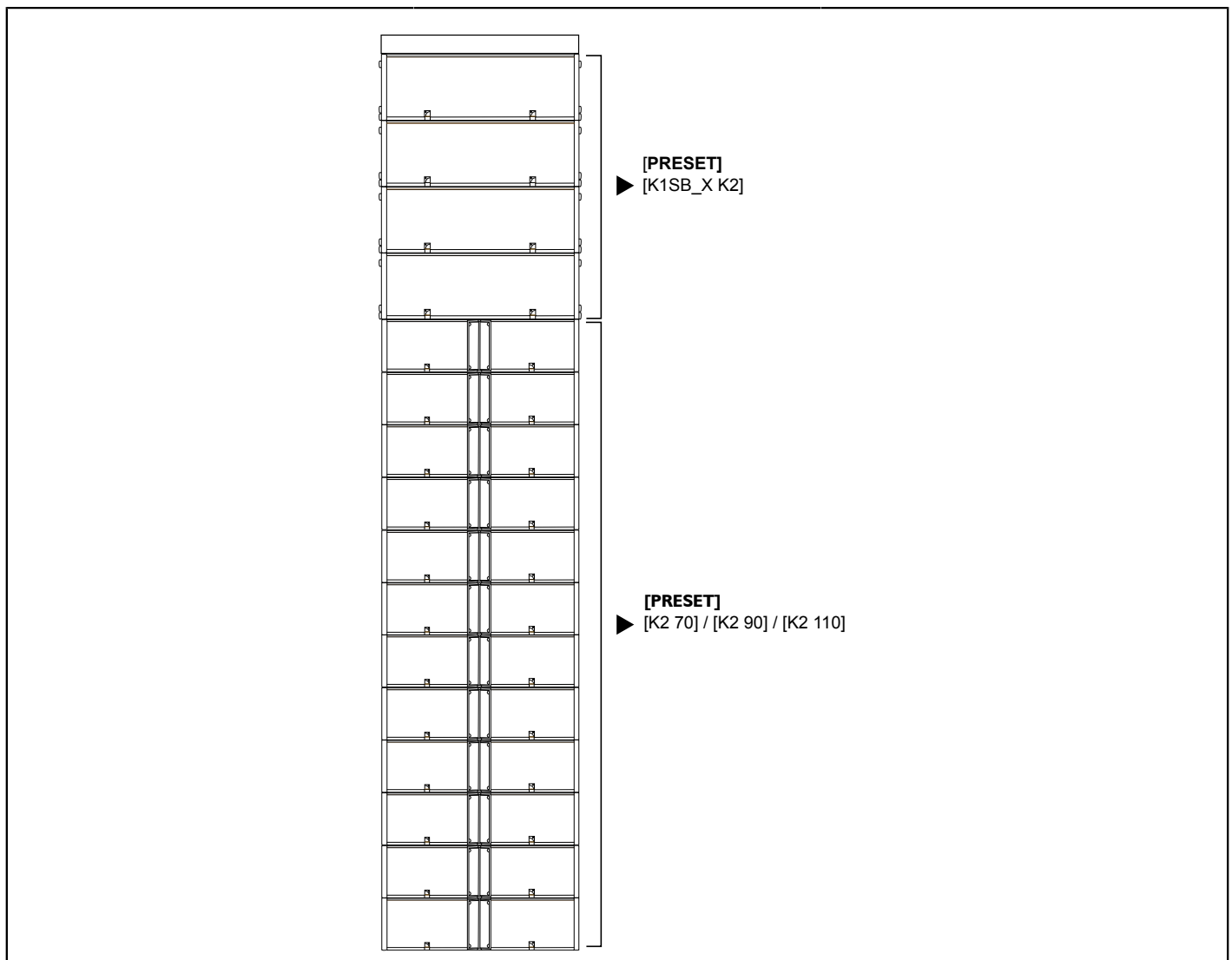
K2/K1-SB line source

Enclosure	K2	K1-SB
Preset	[K2 70] [K2 90] [K2 110]	[K1SB_X K2]
Frequency range (-10 dB)	35 Hz - 20 kHz	
Recommended ratio	3 K2 : 1 K1-SB	
Minimum line length	12 K2 + 4 K1-SB	

! When using [K2 70], [K2 90], or [K2 110] with [K1SB_X K2], do not add any delay value between the K2 and K1-SB elements of a same line source.

Additional subwoofer system

A K2 line source or a K2/K1-SB line source can be deployed with additional subwoofer enclosures to provide increased sub-low resources to demanding applications.

Two subwoofer systems are available:

- K1-SB for increased LF contour
- SB28 for infra extension

The recommended ratio is 3 K2 for 2 subwoofers, whether using K1-SB subwoofers only, SB28 subwoofers only, or a combination of both.

The [K1SB_60] and [SB28_60] presets provide the subwoofers with an upper frequency limit at 60 Hz for an optimal frequency coupling with the line source.

The K1-SB and SB28 subwoofer enclosures are driven by the LA8 amplified controller.

K1-SB

The K1-SB provides an extension of the bandwidth in the low end, down to 30 Hz. Depending on the deployment, LF rejection can be produced.

Three deployments are available in this configuration:

- K1-SB on top of the K2 line source
- K1-SB beside the K2 or K2/K1-SB line source : side LF rejection (polarized)
- K1-SB behind the K2 or K2/K1-SB line source : rear LF rejection (cardioid)

Line source with K1-SB on top

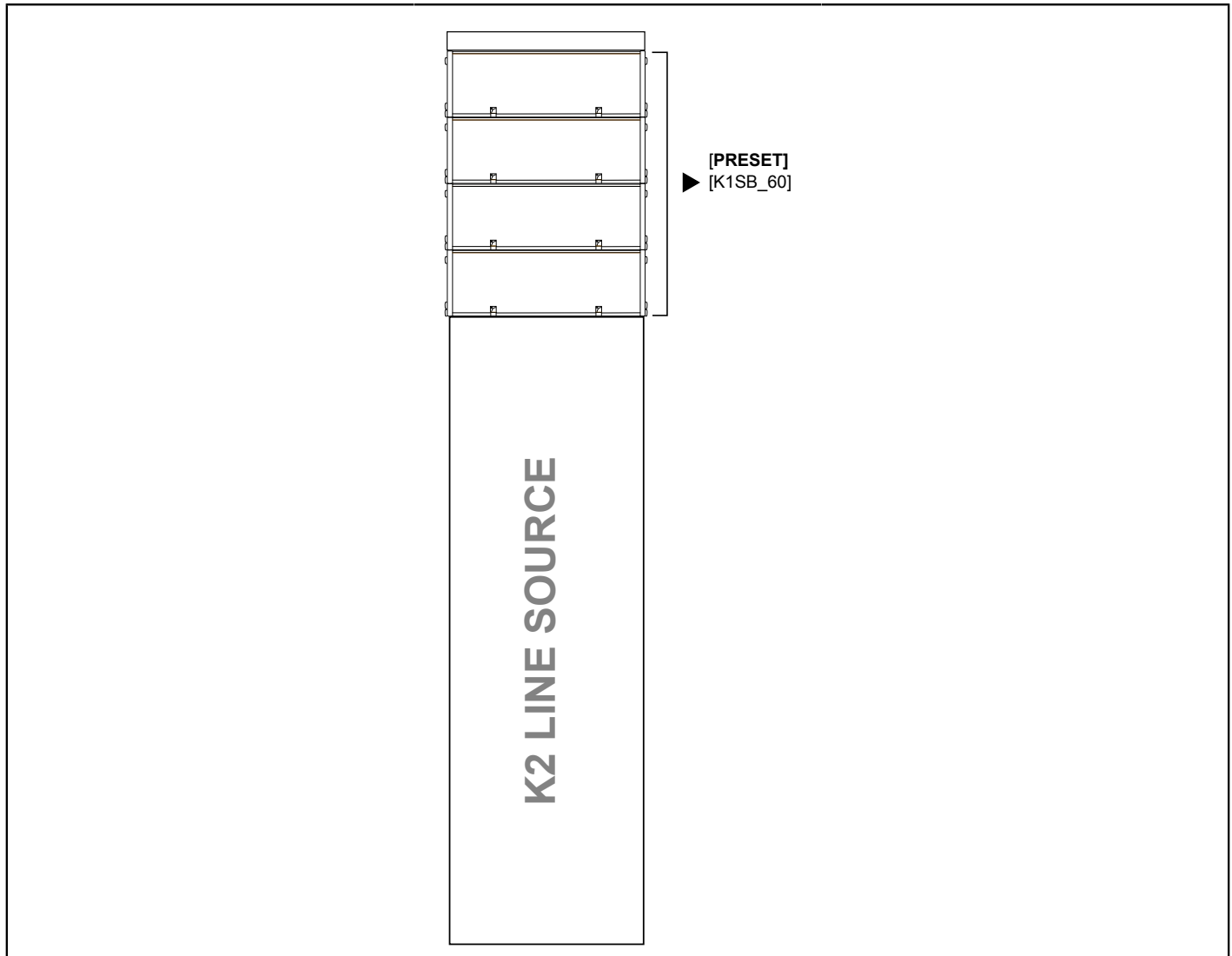

Enclosure	K2	K1-SB as subwoofer
Preset	[K2 70][K2 90][K2 110]	[K1SB_60]
Frequency range (-10 dB)	30 Hz - 20 kHz	
Recommended ratio	3 K2 : 2 subwoofers	
Maximum number line length	12 K2 + 4 K1-SB	



Delay values

Do not forget to add the pre-alignment and geometric delays depending on the configuration.

Pre-alignment delays

[K2] + [K1SB_60]	K2 = 6 ms	K1-SB = 0 ms
------------------	-----------	--------------

Line source with K1-SB beside

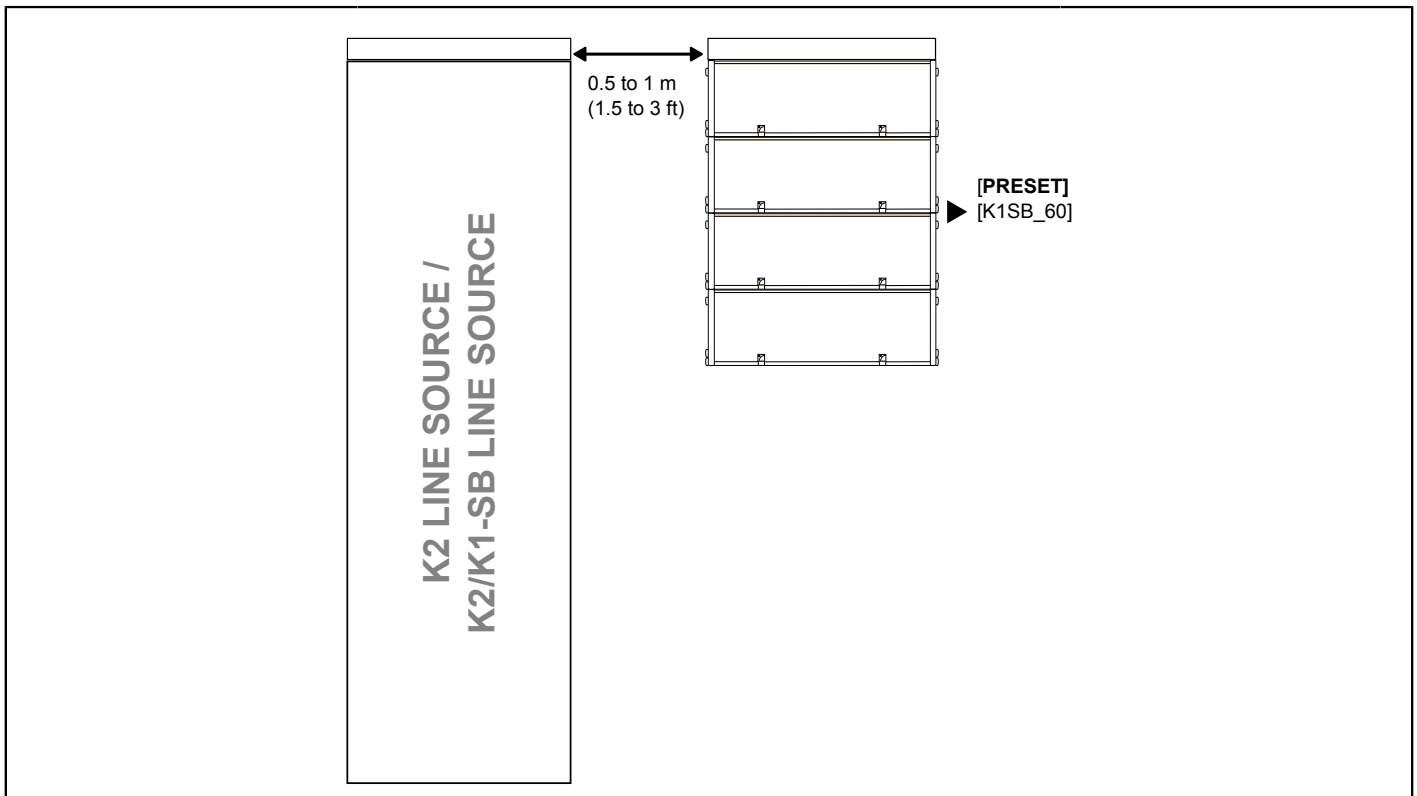

Enclosure	K2	K1-SB in line source	K1-SB as subwoofer
Preset	[K2 70][K2 90][K2 110]	[K1SB_X K2]	[K1SB_60]
Frequency range (-10 dB)	30 Hz - 20 kHz		
Recommended ratio	3 K2 : 2 subwoofers		
Recommended spacing between side panels	Between 0.5 m (1.5 ft) and 1 m (3 ft)		

- ! Delay values**
Do not forget to add the pre-alignment and geometric delays depending on the configuration.
- !** When using [K2 70], [K2 90], or [K2 110] with [K1SB_X K2], do not add any delay value between the K2 and K1-SB elements of a same line source.

Pre-alignment delays

[K2] + [K1SB_60]	K2 = 6 ms	K1-SB = 0 ms
------------------	-----------	--------------

Line source with K1-SB behind

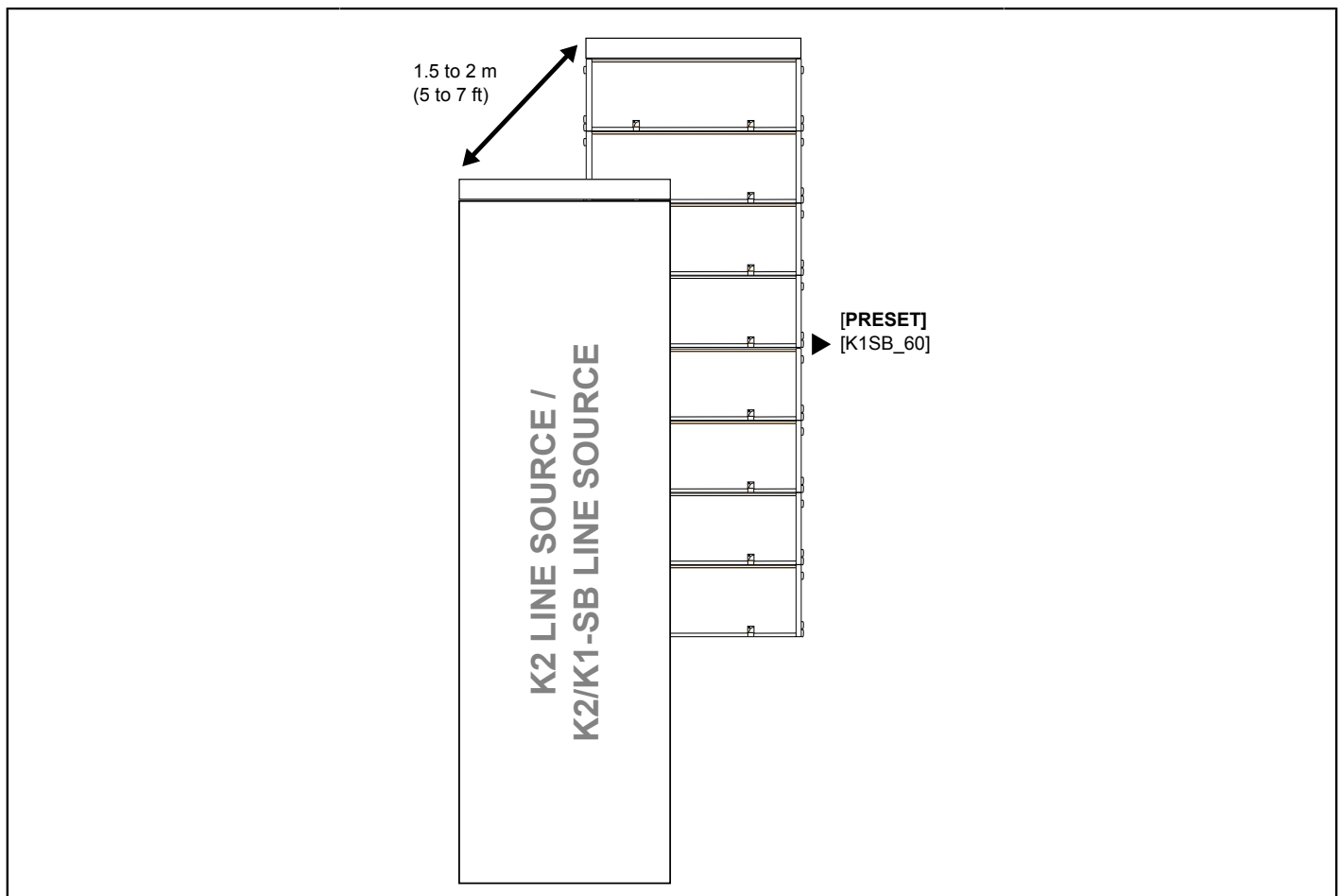

Enclosure	K2	K1-SB in line source	K1-SB as subwoofer
Preset	[K2 70][K2 90][K2 110]	[K1SB_X K2]	[K1SB_60]
Frequency range (-10 dB)	30 Hz - 20 kHz		
Recommended ratio	3 K2 : 2 subwoofers		
Recommended spacing between front faces	Between 1.5 m (5 ft) and 2 m (7 ft)		

! Delay values

Do not forget to add the pre-alignment and geometric delays depending on the configuration.

! When using [K2 70], [K2 90], or [K2 110] with [K1SB_X K2], do not add any delay value between the K2 and K1-SB elements of a same line source.

Pre-alignment delays

[K2] + [K1SB_60]	K2 = 6 ms	K1-SB = 0 ms
------------------	-----------	--------------

Geometric delays

1.5 m (5 ft)	Line source = 4.5 ms
2 m (7 ft)	Line source = 6 ms

SB28

The SB28 provides an extension of the bandwidth in the low end, down to 25 Hz.

Line source with SB28

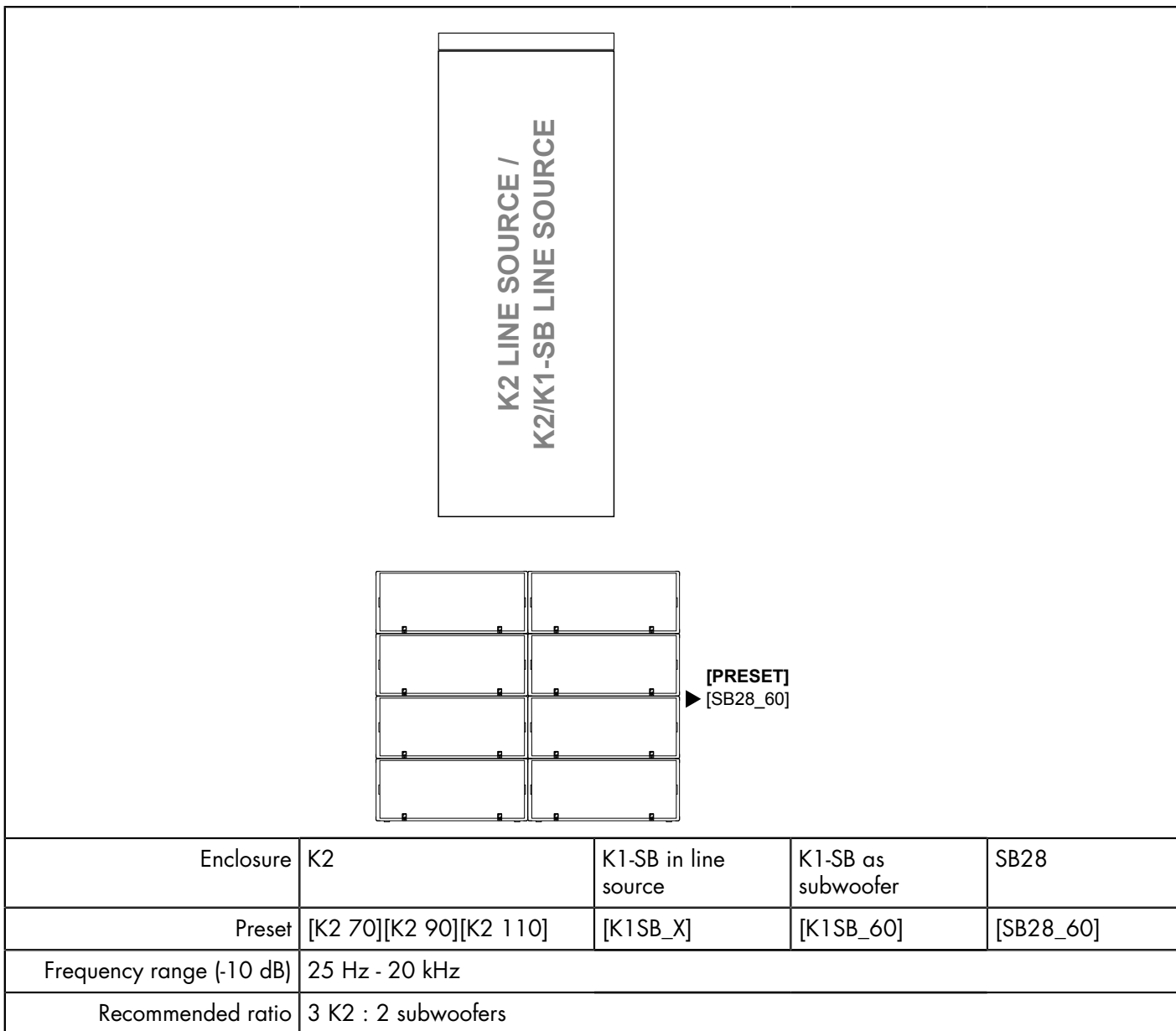

Grouping subwoofers

Place the subwoofer enclosures side by side. If not possible, the maximum distance between two adjacent acoustic centers must be 2.8 m or 1.7 m if the upper frequency limit of the subwoofer system is at 60 Hz or 100 Hz, respectively.



Use [xxxx_xx_C] on a reversed subwoofer in a cardioid configuration

The cardioid configuration consists in reversing 1 element in an array of 4 subwoofers. Refer to the subwoofer user manual and to the **Cardioid configurations** technical bulletin.

**Delay values**

Do not forget to add the pre-alignment and geometric delays depending on the configuration.



When using [K2 70], [K2 90], or [K2 110] with [K1SB_X K2], do not add any delay value between the K2 and K1-SB elements of a same line source.

Pre-alignment delays

[K2] + [SB28_60]	K2 = 0 ms	SB28 = 6 ms	
[K2] + [SB28_60_C]	K2 = 0 ms	SB28 = 0.5 ms	
[K2] + [K1SB_60] + [SB28_60]	K2 = 8 ms	K1-SB = 2 ms	SB28 = 0 ms
[K2] + [K1SB_60] + [SB28_60_C]	K2 = 13.5 ms	K1-SB = 7.5 ms	SB28 = 0 ms

Additional downfill element



All K2 system configurations can be combined with an additional Kara line source downfill system. This allows an extension of the vertical coverage to the closer audience.

Kara

The [KARADOWNK2] preset features a high-pass filter at 100 Hz for the low section, along with specific delay settings, in order to optimize the acoustic coupling between the Kara and K2 line sources.

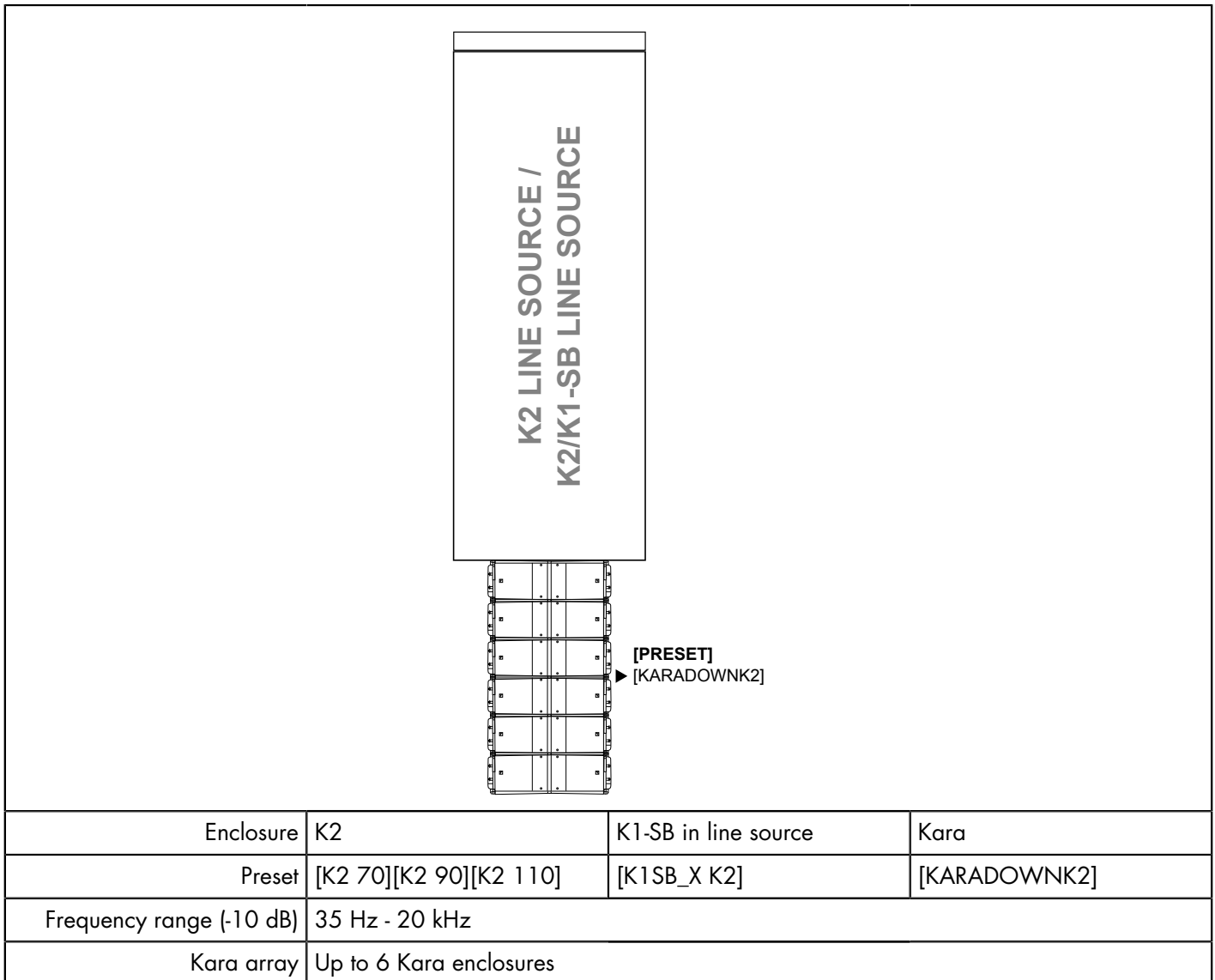
The Kara enclosure is driven by the LA4X / LA8 amplified controller.



-  Do not add any delay between the K2 and Kara elements of a mixed line source.
-  When using [K2 70], [K2 90], or [K2 110] with [K1SB_X K2], do not add any delay value between the K2 and K1-SB elements of a same line source.
-  **Using the Kara system**
 Refer to the **Kara user manual** for the operating modes of Kara as a main system.

Loudspeaker connection

Connectors

Kara is equipped with two 4-point speakON connectors.

Kara

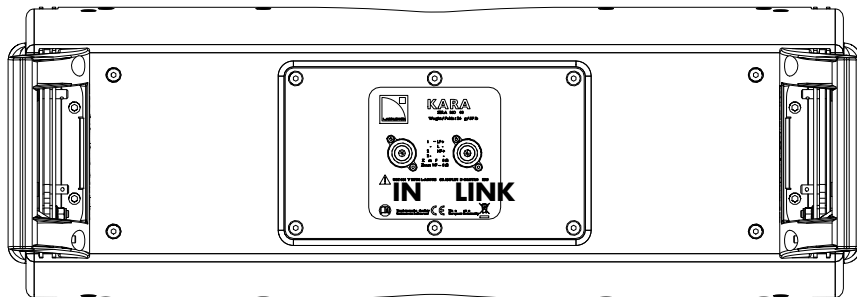

Internal pinout for L-Acoustics 2-way active enclosures

speakON points	1 +	1 -	2 +	2 -
Transducer connectors	LF +	LF -	HF +	HF -

K2 is equipped with two 8-point PA-COM connectors.

K2

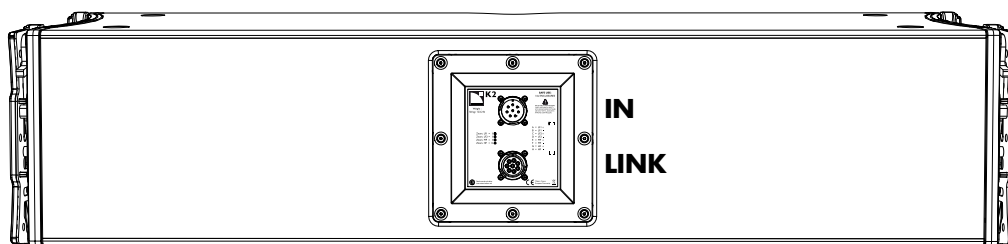

Internal pinout for L-Acoustics 3-way active enclosures

PA-COM points	A/B	C/D	E/F	G/H
Transducer connectors	left LF	right LF	MF	HF

K1-SB is equipped with one 4-point speakON connector.

K1-SB

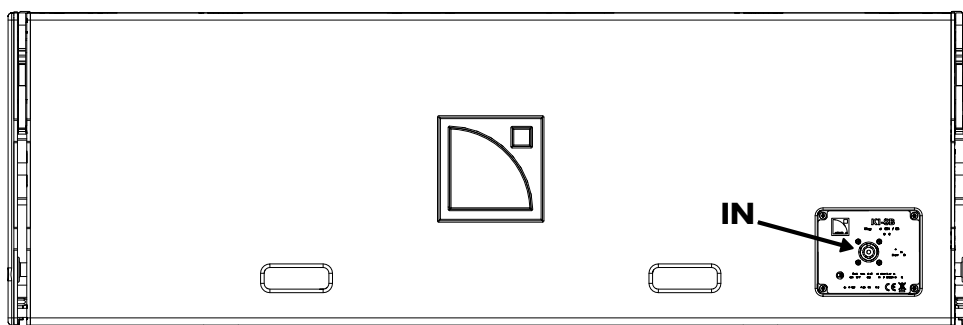

SB28 is equipped with one 4-point speakON connector.

SB28

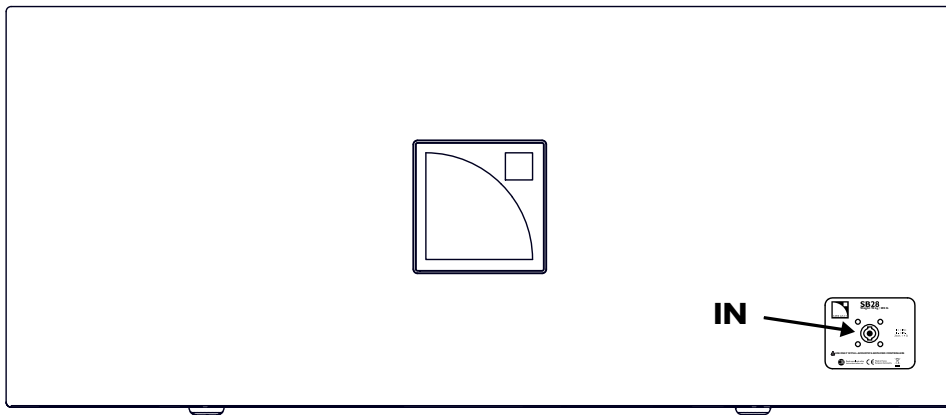

Internal pinout for L-Acoustics subwoofers

speakON points	1 +	1 -	2 +	2 -
Transducer connectors	LF +	LF -	Not linked	Not linked

Connection to LA4X

Maximum number of enclosures per LA4X

enclosure	max enclosures in parallel *	max enclosures per controller
K2	1	1
Kara	2	4

*For passive loudspeakers, the value corresponds to the number of enclosures in parallel on the output. For active loudspeakers, the value corresponds to the number of sections in parallel on the output.

Impedance load

K2

1 enclosure: LF 8 Ω / MF 8 Ω / HF 16 Ω

Kara

1 enclosure: LF 8 Ω / HF 8 Ω

2 enclosures in parallel: LF 4 Ω / HF 4 Ω

Connecting 3-way active enclosures

custom speakON-to-PA-COM on speakON output

i L-Acoustics does not supply the speakON-to-PA-COM interface. It must be built with two 4-point speakON connectors and a female 8-point PA-COM connector (no cable clamp).

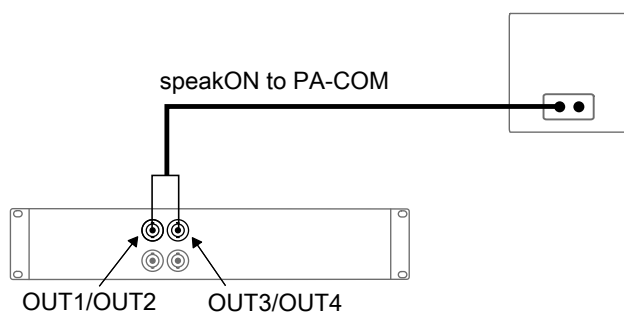

Connecting 2-way active enclosures

SP on speakON output

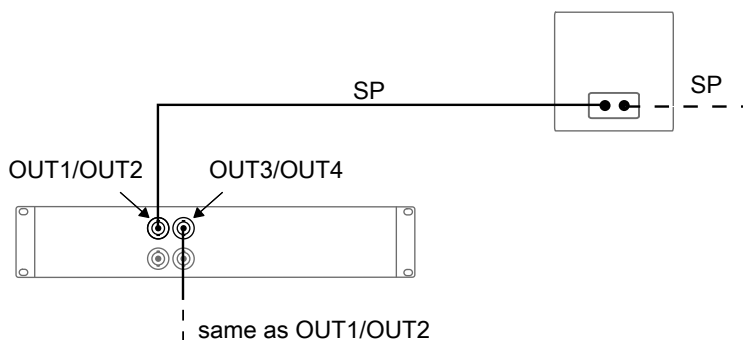

Connection to LA8

Maximum number of enclosures per LA8

enclosure	max enclosures in parallel *	max enclosures per controller
K2	3	3
Kara	3	6
K1-SB	1	4
SB28	1	4

*For passive loudspeakers, the value corresponds to the number of enclosures in parallel on the output. For active loudspeakers, the value corresponds to the number of sections in parallel on the output.

Impedance load

K2

- 1 enclosure: LF 8 Ω / MF 8 Ω / HF 16 Ω
- 2 enclosures in parallel: LF 4 Ω / MF 4 Ω / HF 8 Ω
- 3 enclosures in parallel: LF 2.7 Ω / MF 2.7 Ω / HF 5.2 Ω

Kara

- 1 enclosure: LF 8 Ω / HF 8 Ω
- 2 enclosures in parallel: LF 4 Ω / HF 4 Ω

SB28 K1-SB

- 1 enclosure: 4 Ω

Connecting 3-way active enclosures

DO on CA-COM output

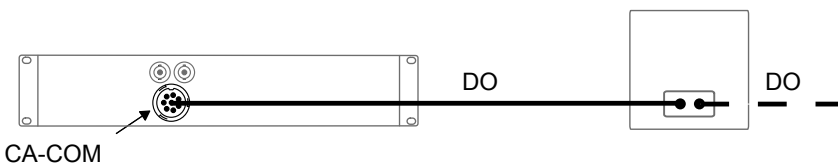

Connecting 2-way active enclosures

SP on speakON output

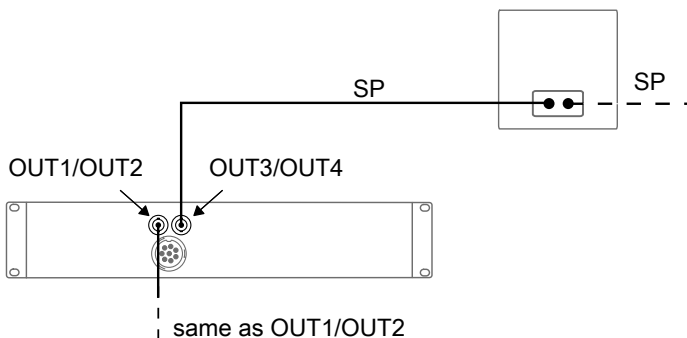

DO and DOFILL-LA8 on CA-COM output

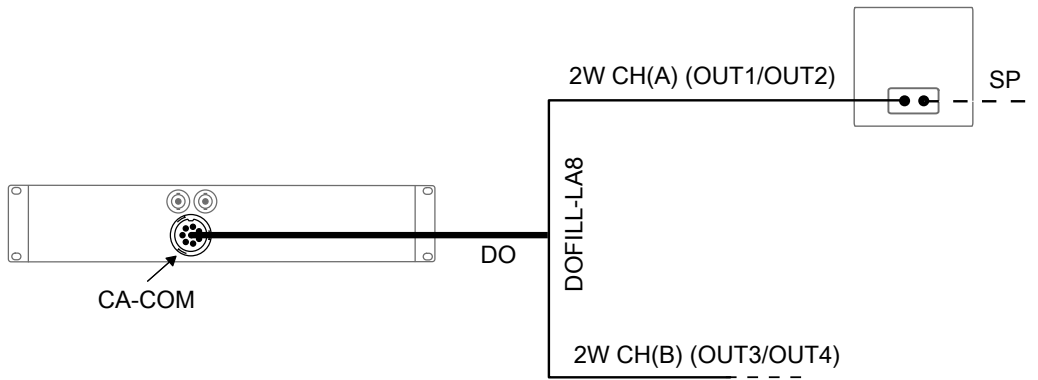

Connecting a 2-way active enclosure with subwoofers

DO and DO3WFILL on CA-COM output

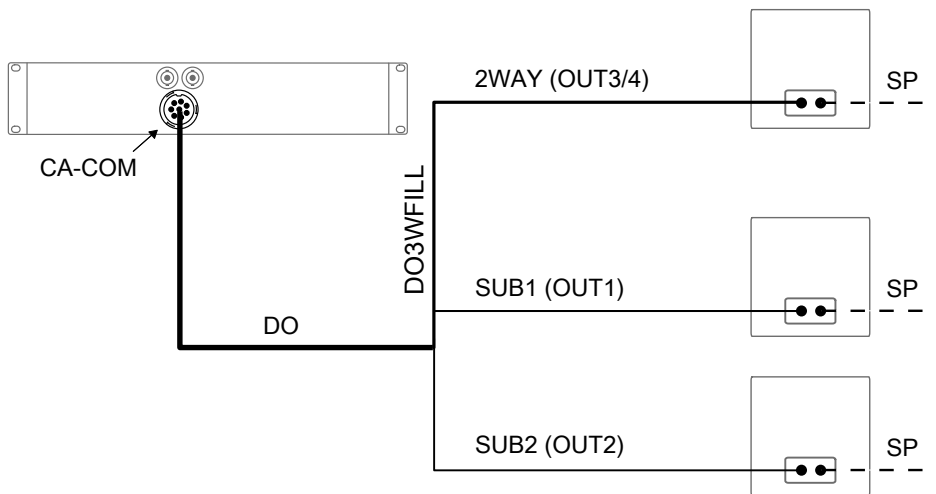

Connecting subwoofers

SP and SP-Y1 on speakON output

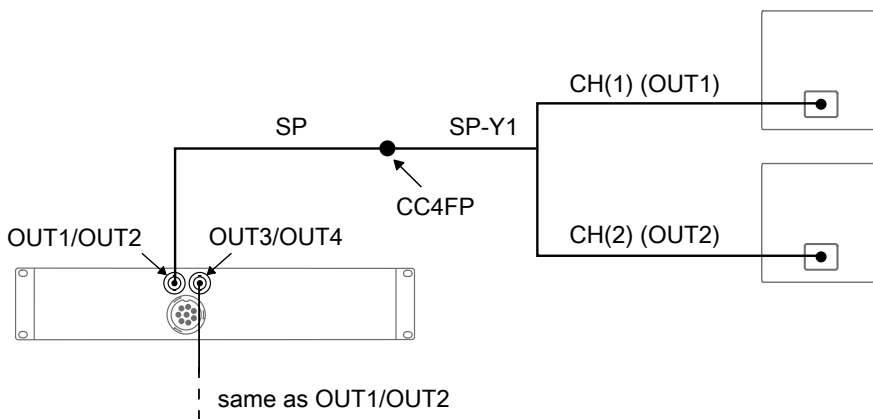

DO and DOSUB-LA8 on CA-COM output

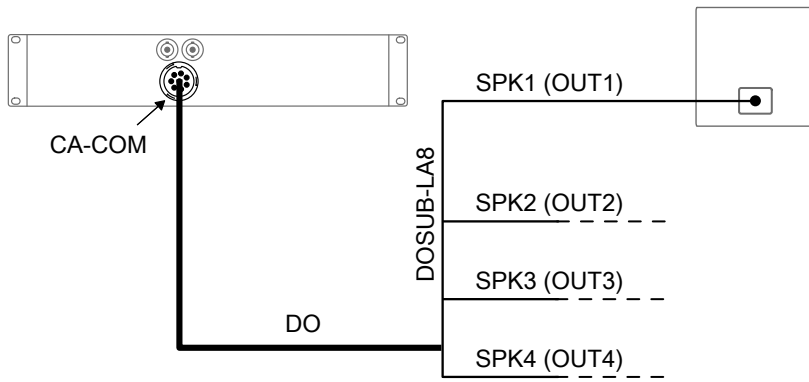

Preset description

[K2 70] [K2 90] [K2 110]

loudspeaker elements	outputs	channels	routing	gain	delay	polarity	mute
left LF	OUT 1	LF	IN A	0 dB	0 ms	+	ON
right LF	OUT 2	LF					ON
MF	OUT 3	MF					ON
HF	OUT 4	HF					ON

[KARADOWNK2]

loudspeaker elements	outputs	channels	routing	gain	delay	polarity	mute
LF	OUT 1	LF	IN A	0 dB	0 ms	+	ON
HF	OUT 2	HF					ON
LF	OUT 3	LF	IN A	0 dB	0 ms	+	ON
HF	OUT 4	HF					ON

[K1SB_60] [K1SB_X K2] [SB28_60]

outputs	channels	routing	gain	delay	polarity	mute
OUT 1	SB	IN A	0 dB	0 ms	+	ON
OUT 2	SB	IN A	0 dB	0 ms	+	ON
OUT 3	SB	IN A	0 dB	0 ms	+	ON
OUT 4	SB	IN A	0 dB	0 ms	+	ON

[SB28_60_C]

loudspeaker elements	outputs	channels	routing	gain	delay	polarity	mute
SR	OUT 1	SR	IN A	0 dB	0 ms	+	ON
SB	OUT 2	SB					ON
SB	OUT 3	SB					ON
SB	OUT 4	SB					ON

Recommendation for speaker cables

Follow the recommended maximum length for loudspeaker cables to ensure minimal SPL attenuation.



Cable quality and resistance

Only use high-quality fully insulated speaker cables made of stranded copper wire.

Use cables with a gauge offering low resistance per unit length and keep the cables as short as possible.

The table below provides the recommended maximum length for loudspeaker cables depending on the cable gauge and on the impedance load connected to the amplifier.

cable gauge			recommended maximum length					
			8 Ω load		4 Ω load		2.7 Ω load	
mm ²	SWG	AWG	m	ft	m	ft	m	ft
2.5	15	13	30	100	15	50	10	33
4	13	11	50	160	25	80	17	53
6	11	9	74	240	37	120	25	80

For your installation projects, you can use the more detailed L-ACOUSTICS calculation tool to evaluate cable length and gauge based on the type and number of enclosures connected. The calculation tool is available on our website:

<http://www.l-acoustics.com/installation-outils-de-calcul-137.html>

Specifications

K2 specifications

Description	3-way full-range active WST enclosure , quad-amplified by LA4X / LA8
Usable bandwidth (-10 dB)	35 Hz - 20 kHz ([K2 70])
Maximum SPL¹	147 dB ([K2 70])
Nominal directivity	horizontal: 110°/70° symmetric or 90° asymmetric (35°/55° or 55°/35°) vertical: dependent upon the number of elements and the line source curvature
Transducers	LF: 2 × 12" cone drivers MF: 4 × 6.5" cone drivers HF: 2 × 3" diaphragm compression drivers
Acoustical load	LF: bass-reflex, L-Vents MF: bass-reflex HF: DOSC waveguides
Nominal impedance	LF: 2 × 8 Ω MF: 8 Ω HF: 16 Ω
Connectors	IN: 1 × 8-point PA-COM LINK: 1 × 8-point PA-COM
Rigging and handling	captive 4-point rigging system inter-enclosure angles: 0.25°, 1°, 2°, 3°, 4°, 5°, 7.5° or 10°
Weight (net)	56 kg / 123.2 lb
Cabinet	first grade Baltic birch plywood
Front	steel grill with anti-corrosion coating acoustically neutral 3D fabric
Rigging components	high grade steel with anti-corrosion coating
Finish	dark grey brown Pantone 426C
IP	IP45

¹ Peak level measured at 1 m under free field conditions using pink noise with crest factor 4 (preset specified in brackets).

K2 dimensions

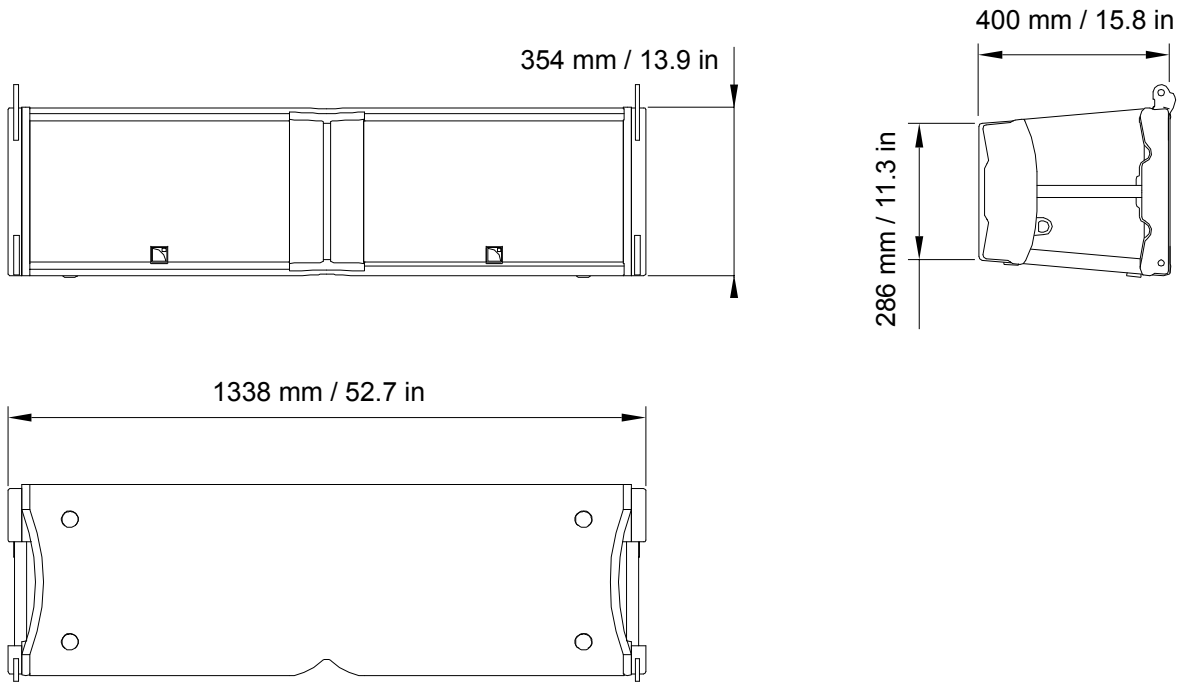

Kara specifications

Description	2-way modular WST enclosure, bi-amplified by LA4X / LA8
Usable bandwidth (-10 dB)	55 Hz - 20 kHz ([KARA])
Maximum SPL¹	141 dB ([KARA])
Nominal directivity	horizontal: 110° symmetric vertical: dependent upon the number of elements and the line source curvature
Transducers	LF: 2 × 8" neodymium cone drivers HF: 1 × 3" neodymium diaphragm compression driver
Acoustical load	LF: bass-reflex HF: DOSC waveguides
Nominal impedance	LF: 8 Ω HF: 8 Ω
Connectors	IN: 1 × 4-point speakON LINK: 1 × 4-point speakON
Rigging and handling	captive rigging system handles integrated into the cabinet inter-enclosure angles: 0°, 1°, 2°, 3°, 4°, 5°, 7.5° or 10°
Weight (net)	26 kg / 57 lb
Cabinet	first grade Baltic birch plywood
Front	steel grill with anti-corrosion coating acoustically neutral 3D fabric
Rigging components	high grade steel with anti-corrosion coating
Finish	dark grey brown Pantone 426C
IP	IP45

¹ Peak level measured at 1 m under free field conditions using pink noise with crest factor 4 (preset specified in brackets).

Kara dimensions

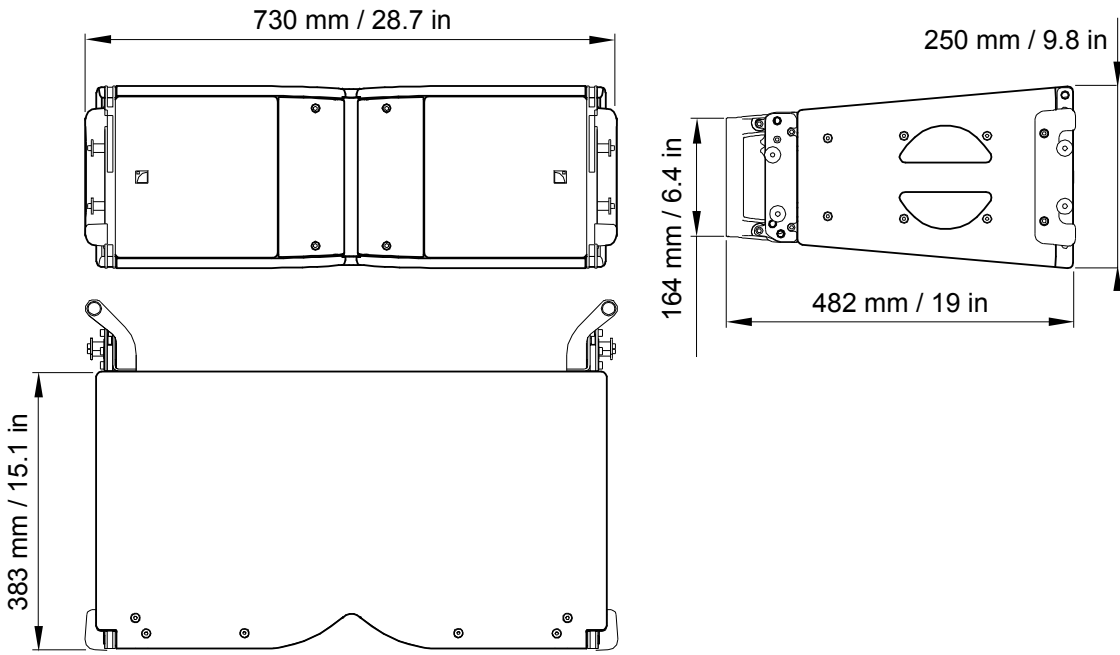

K1-SB specifications

Description	K1 system subwoofer 2×15" , amplified by LA8
Low frequency limit (-10 dB)	30 Hz ([K1SB_60])
Maximum SPL¹	145 dB ([K1SB_X])
Transducers	2 × 15" cone drivers
Acoustical load	bass-reflex, L-Vents
Nominal impedance	4 Ω
Connectors	IN: 1 × 4-point speakON
Rigging and handling	captive 4-point rigging system inter-enclosure angles: 0°, 0.5°, 1°, 1.5°, 2°, 2.5°, 3°, 4° or 5° handles integrated into the cabinet
Weight (net)	83 kg / 183 lb
Cabinet	first grade Baltic birch plywood
Front	steel grill with anti-corrosion coating acoustically neutral 3D fabric
Rigging components	high grade steel with anti-corrosion coating
Finish	dark grey brown Pantone 426C
IP	IP45

¹ Peak level at 1 m under half space conditions using pink noise with crest factor 4 (preset specified in brackets).

K1-SB dimensions

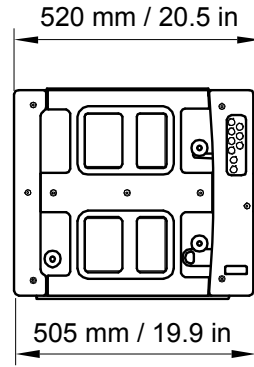
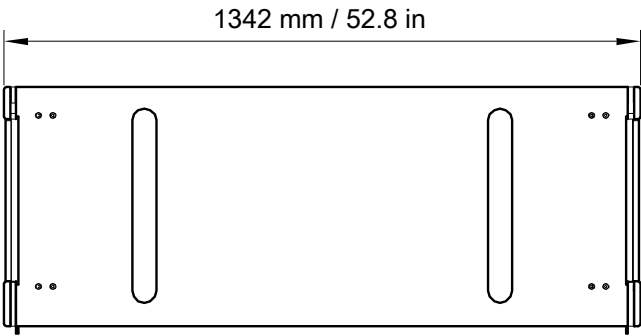
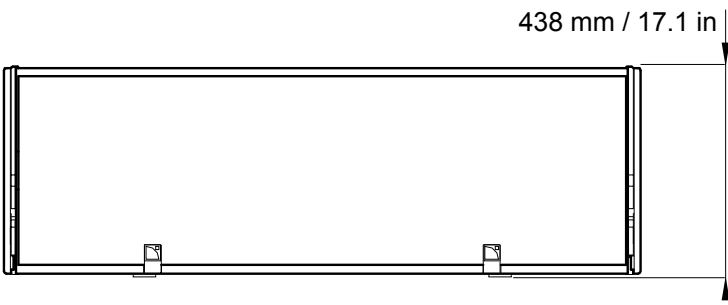

SB28 specifications

Description	High power subwoofer: 2 x 18" , amplified by LA8
Low frequency limit (-10 dB)	25 Hz ([SB28_100])
Maximum SPL¹	142 dB ([SB28_100])
Directivity	standard or cardioid
Transducers	2 x 18" neodymium cone drivers
Acoustical load	bass-reflex, L-Vents
Nominal impedance	4 Ω
Connectors	IN: 1 x 4-point speakON
Rigging and handling	integrated rigging system handles integrated into the cabinet
Weight (net)	93 kg / 205 lb
Cabinet	first grade Baltic birch plywood
Front	steel grill with anti-corrosion coating acoustically neutral 3D fabric
Rigging components	high grade steel with anti-corrosion coating
Finish	dark grey brown Pantone 426C

¹ Peak level at 1 m under half space conditions using pink noise with crest factor 4 (preset specified in brackets).

SB28 dimensions

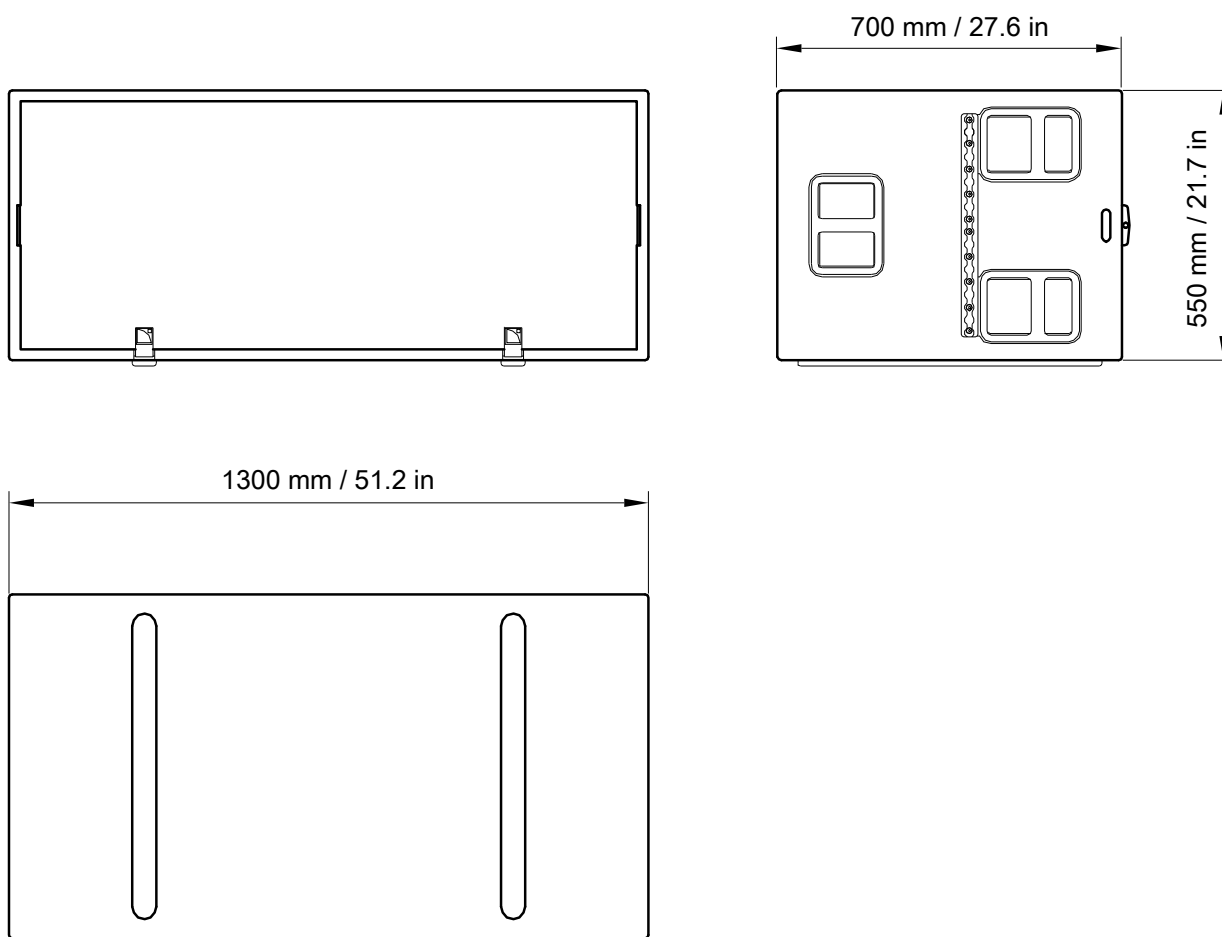



L-Acoustics, an L-Group Company

13 rue Levacher Cintrat - 91460 Marcoussis - France
+33 1 69 63 69 63 - info@l-acoustics.com
www.l-acoustics.com

L-Acoustics GmbH

Steiermärker Str. 3-5
70469 Stuttgart
Germany
+49 7 11 89660 323

L-Acoustics Ltd.

PO. Box Adler Shine - Aston House
Cornwall Avenue - London N3 1LF
United Kingdom
+44 7224 11 234

L-Acoustics Inc.

2645 Townsgate Road, Suite 600
Westlake Village, CA 91361
USA
+1 805 604 0577



L-GROUP

www.l-group.com